

Tunable Infrared Metasurface based on VO₂ for Anti-Counterfeiting and Adaptive Radiative Cooling

Junichi Takahara^{1,2}

¹Graduate School of Engineering, Osaka University, Suita, Osaka, Japan

²Photonics Center, Graduate School of Engineering Osaka University, Suita, Osaka, Japan

*corresponding author, E-mail: takahara@ap.eng.osaka-u.ac.jp

Abstract

We demonstrate tunable infrared metasurface by utilizing metal-insulator transition material of VO₂. Switching optical property between dielectric and negative dielectric opens new functionality of metasurface such as anti-counterfeiting and adaptive radiative cooling in wide range of spectra from near- to mid-IR range.

1. Introduction

Metasurface is two-dimensional ensemble of meta-atoms. The scattering and absorption of metasurface can be controlled by materials, shapes or arrangements of an individual meta-atom. Figure 1 shows schematic view of various meta-atoms showing different types of functions.

Dielectric structural colors based on a single crystal silicon (Si) Mie resonator (Fig. 1(a) and (b)) have been demonstrated with the resolution of 80,000 dots per inch (dpi) [1]. By adding a Cr cap layer to the top of Mie resonator (Fig. 1(b)), we are able to control the resonance of electric dipole, resulting in achieving the diffraction-limited resolution of 100,000 dpi. Such high resolution of structural colors is useful for applications to anti-counterfeiting color images [1]. However, the image can be easily observed by conventional optical microscope. Hence, it is natural to extend from visible image to near-infrared (IR) image in order to protect easy access by microscope.

In this paper, we report tunable IR pixels based on metal-insulator transition material of VO₂ and its application to tunable IR image and adaptive radiative cooling by changing temperature.

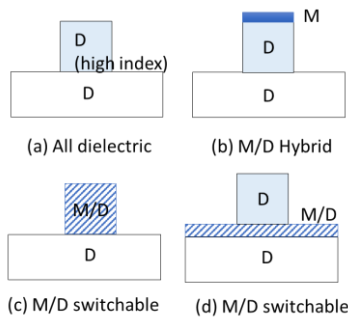

Figure 1: Cross sectional view of various meta-atoms: (a) all-dielectric, (b) M/D hybrid, and (c) and (d) M/D switchable (D: dielectric, M: metal).

2. Tunable metasurface based on VO₂

Since transition temperature of VO₂ is 340K, the permittivity of VO₂ ϵ can be changed from positive ($\epsilon > 0$) to negative ($\epsilon < 0$) drastically in near-IR range by temperature. Such change in ϵ induces great change of reflectance of the metasurface. Thus, by replacing the material of Mie resonator from Si to VO₂, we are able to realize tunable “color” pixels at near-IR [2]. Figure 1(c) and (d) show schematically tunable meta-atoms between dielectric ($\epsilon > 0$) and metal ($\epsilon < 0$).

Figure 2 shows scanning ion microscope image of cylindrical VO₂ metasurface. Here, at first 400nm-thickness VO₂ thin film was deposited by pulse laser deposition on the (0001) sapphire substrate. After that, we fabricated cylindrical array by electron beam lithography and reactive ion etching.

Figure 3 shows IR microscope image of VO₂ metasurface observed by IR objective lens through bandpass filter at 1.5 μ m. As seen in Fig. 3(b), hidden characters of “HOT” were clearly observed only above transition temperature of 340K. The resolution of the image exceeds 39,000 dpi at 1.5 μ m. We can embed hidden messages into the metasurface which can be observed only at near-IR.

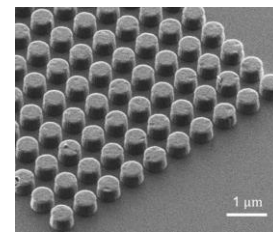

Figure 2 Scanning ion microscope image of cylindrical VO₂ metasurface formed on sapphire substrate.

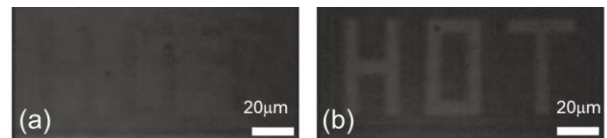

Figure 3: IR Microscope image of VO₂ metasurface at 1.5 μ m: (a) T=298K and (b) 348K [2].

In addition, we will propose and discuss about adaptive radiative cooling device based on Mie resonator in atmospheric window of 8-13 μm utilizing VO₂ metasurface. In this device, we are able to control emissivity with depending on environmental temperature. Such devices are useful from the viewpoint of active thermal radiation control in mid-IR range [3].

Acknowledgements

This work was supported by JSPS KAKENHI Grant Number JP19H02630 and the JSPS Core-to-Core Program, A. Advanced Research Networks (Advanced Nanophotonics in the Emerging Fields of Nano-imaging, Spectroscopy, Nonlinear Optics, Plasmonics/ Metamaterials and Devices).

References

- [1] Y. Nagasaki, I. Hotta, M. Suzuki, and J. Takahara, *ACS Photonics* 5, 3849 (2018).
- [2] Y. Nagasaki, T. Kohno, K. Bando, H. Takase, K. Fujita, and J. Takahara, *Appl. Phys. Lett.* 115, 161105 (2019).
- [3] H. Toyoda, K. Kimino, A. Kawano and J. Takahara, *Photonics*, 6(4), 105 (2019).